

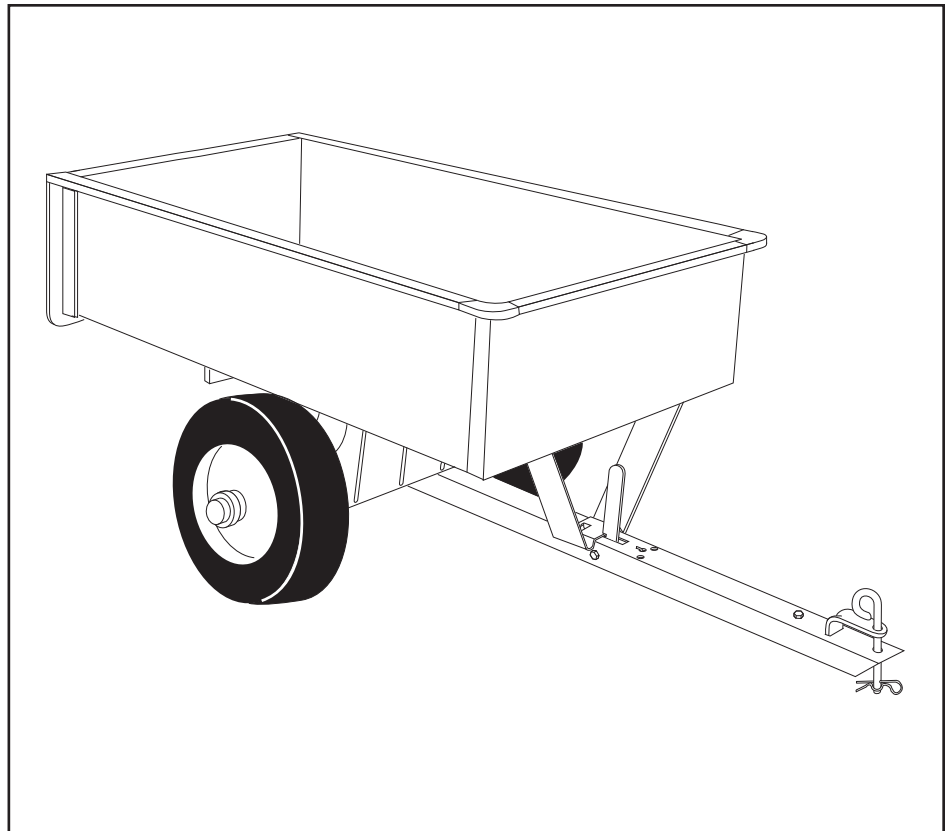

OWNERS MANUAL

Model No.'s
45-01012
190-653B



UTILITY CARTS

(SEE SPECIFICATIONS ON PAGE 7)

CAUTION:
Read Rules for
Safe Operation
and Instructions
Carefully

- Assembly
- Operation
- Maintenance
- Repair Parts

SpeedPart *the fastest way to purchase parts* www.speedepart.com

SAFETY RULES

Remember, any power equipment can cause injury if operated improperly or if the user does not understand how to operate the equipment. Exercise caution at all times when using power equipment.



LOOK FOR THIS SYMBOL TO POINT OUT IMPORTANT SAFETY PRECAUTIONS. IT MEANS — ATTENTION! BECOME ALERT! YOUR SAFETY IS INVOLVED.



CAUTION: VEHICLE BRAKING AND STABILITY MAY BE AFFECTED WITH THE ADDITION OF AN ACCESSORY OR AN ATTACHMENT. BE AWARE OF CHANGING CONDITIONS ON SLOPES.

Exercise caution at all times when using power equipment.

- Read this owners manual before attempting to assemble or operate the cart.
- Read the vehicle owners manual and know how to operate your tractor, before using the cart attachment.
- Do not at any time carry passengers in this cart. It has not been designed to carry passengers.
- Never allow children to operate the tractor or the cart attachment.
- Do not allow adults to operate the tractor or cart attachment without proper instructions.
- Always begin with the transmission in first (low) and gradually increase speed as conditions permit.
- Tow the cart at reduced speed over rough terrain and hillsides or near creeks and ditches to prevent tipping over and loss of control. Do not drive too close to a creek or ditch.
- Vehicle braking and stability may be affected with the attachment of this cart. Do not fill cart to maximum weight capacity without checking the capability of the towing vehicle to safely pull and stop with the cart attached.
- Before operating vehicle on any grade (hill) refer to the safety rules in the vehicle owner's manual concerning safe operation on slopes. Refer also to the slope guide on page 11 of this manual. **Stay off steep slopes!**
- Do not tow this cart on highways or on public thoroughfares.
- Maximum towing speed is 10 m.p.h.
- Follow maintenance and lubrication instructions as outlined in this manual.

CARTON CONTENTS (Loose Parts)

- | | | |
|------------------------|-----------------------------------|---------------------|
| 1. Tailgate Guides (2) | 5. Latch Stand Bracket | 9. Wheel Support |
| 2. Corner Caps (2) | 6. Tailgate Reinforcement Bracket | 10. Axle |
| 3. Latch Lock Lever | 7. Tailgate | 11. Draw Bar Tongue |
| 4. Hitch Bracket | 8. Front Panel | 12. Cart Body (2) |
| | | 13. Wheels (2) |

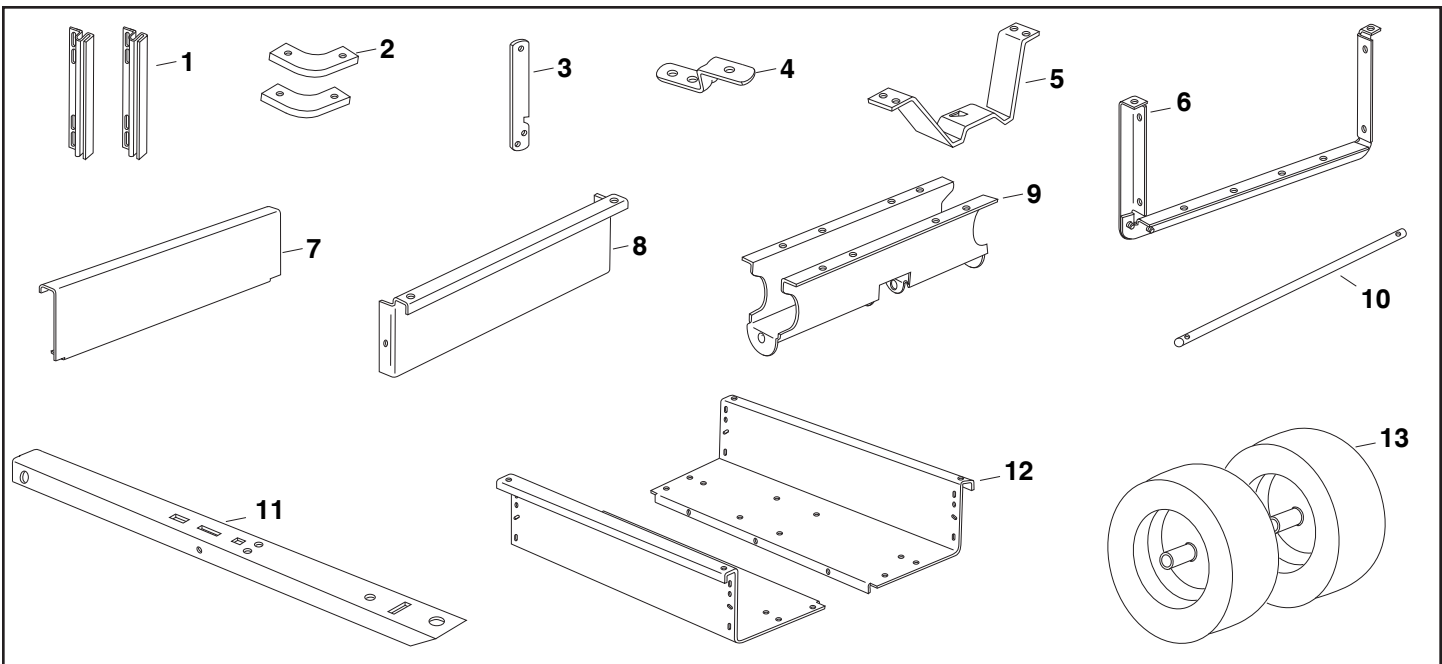

CARTON CONTENTS

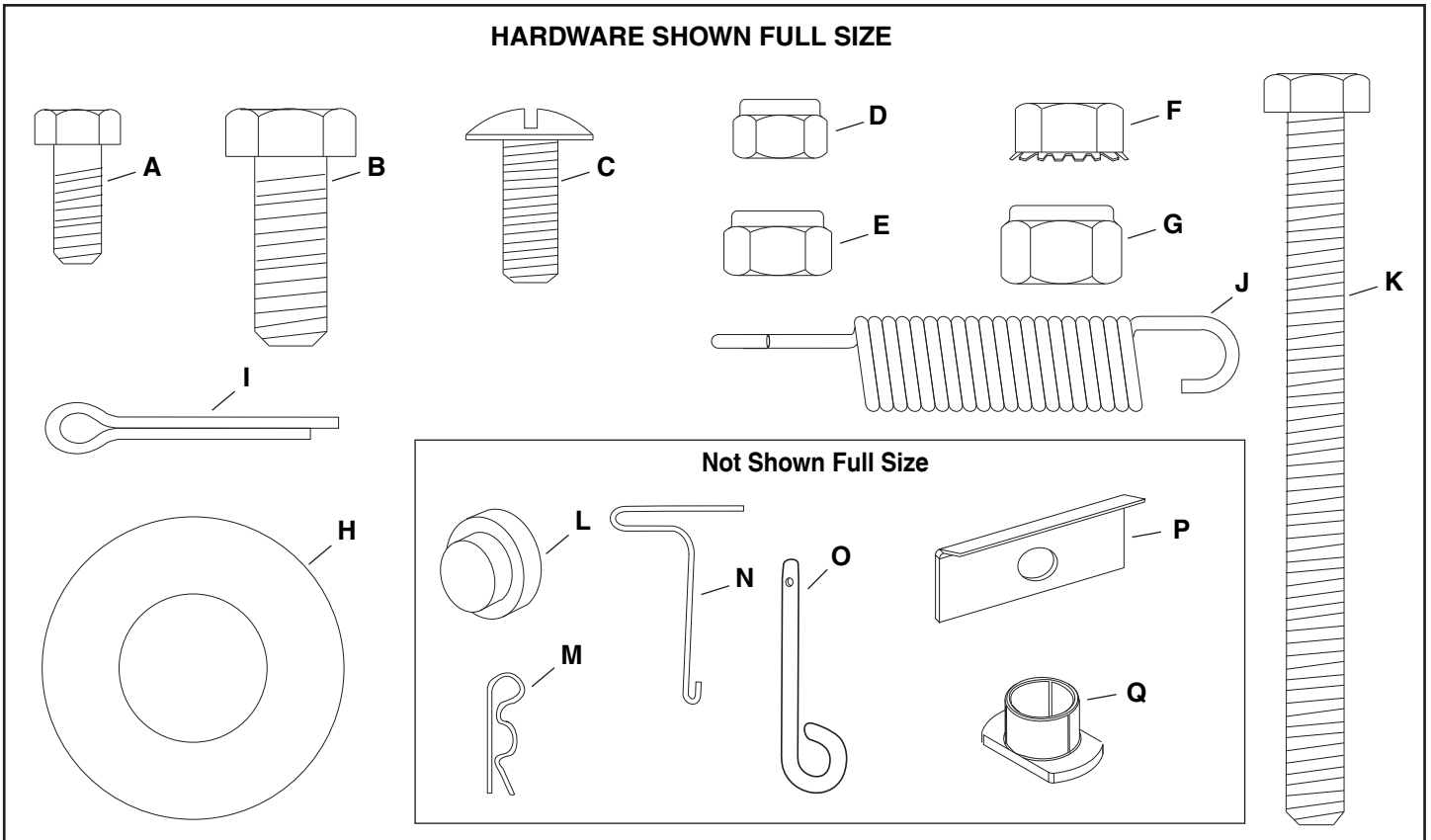

FIGURE 1 - HARDWARE PACK

Ref.	Description	Quantity
A	Hex Bolt, 1/4" x 5/8"	21
B	Hex Bolt, 3/8" x 1"	1
C	Truss Hd. Bolt, 5/16" x 3/4" Lg.	12
D	Nylock nut, 1/4"	21
E	Nylock nut, 5/16"	14
F	Hex Lock Nut, 5/16" (SEMS)	2
G	Nylock nut, 3/8"	1
H	Flat Washer, 3/4"	6
I	Cotter Pin, 1/8" x 1" Lg.	2
J	Spring	1
K	Hex Bolt 5/16-18 x 3-3/4"	1
L	Hub Cap	2
M	Hair Cotter Pin 1/8"	1
N	Spring Puller Tool	1
O	Hitch Pin	1
P	Axle Clip	2
Q	Flange Bearing	2

ASSEMBLY INSTRUCTIONS

TOOLS REQUIRED FOR ASSEMBLY

- (1) Screwdriver
- (1) Pliers
- (2) 7/16" Wrenches
- (2) 1/2" Wrench
- (2) 9/16" Wrenches

1. Remove the hardware pack and all loose parts from the carton. Be sure the carton is empty before discarding.
2. Lay out all parts as shown in the carton contents.

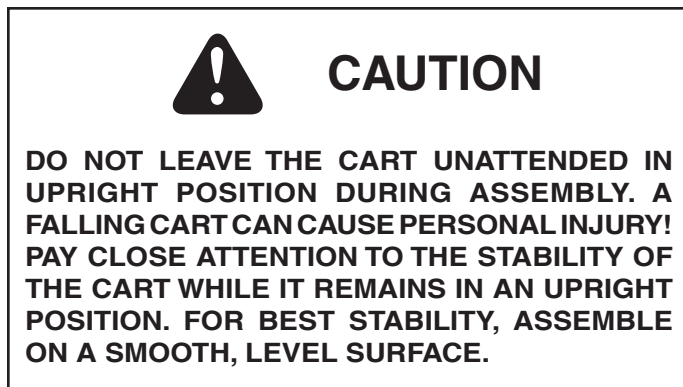

3. Position cart body halves upright on a smooth level surface such as a garage floor or a paved driveway. See figure 2.
4. Assemble halves together using three 1/4" x 5/8" hex bolts and 1/4" nylock nuts as shown in figure 2. **Do not tighten.**

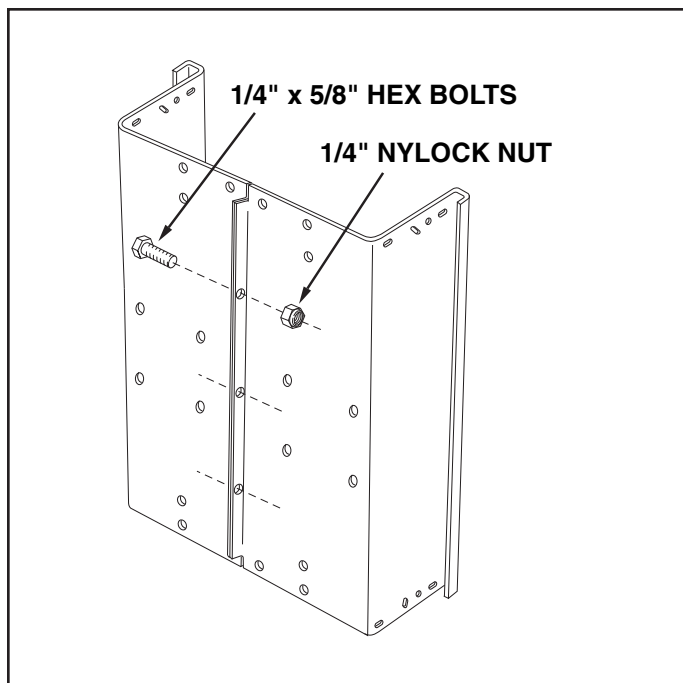

FIGURE 2

5. Position the tailgate reinforcement bracket on outside of cart as shown in figure 3. Assemble to the bottom of the cart body using four 5/16" x 3/4" truss head bolts and 5/16" nylock nuts. **Do not tighten.** See figure 3.
6. Position the tailgate guides on the inside of the cart bodies with guide channels to the front as shown in figure 3. Assemble using four 1/4" x 5/8" hex bolts and 1/4" nylock nuts. **Do not tighten.**

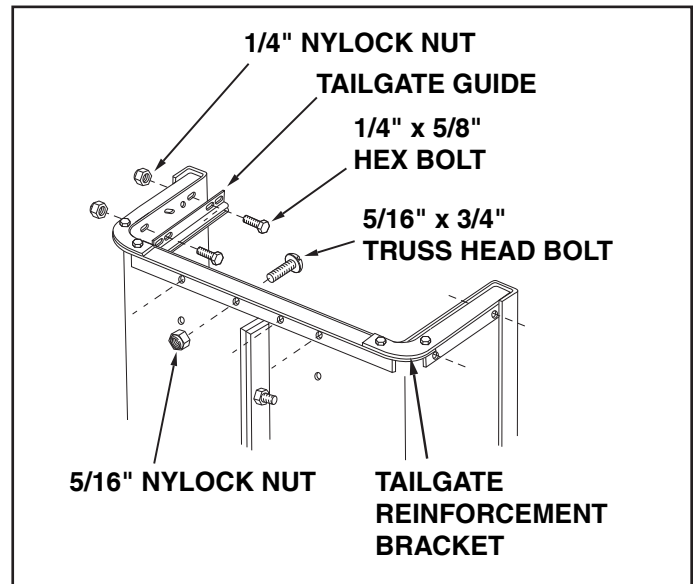

FIGURE 3

7. At this time, with the cart body halves pulled together, **tighten** the four truss head bolts assembled in step 5 and then **tighten** the four hex bolts assembled in step 6. **Do not tighten** the three hex bolts that were assembled in step 4.
8. Carefully reverse the position of the cart so that it rests on the tailgate reinforcement bracket, as shown in figure 4.

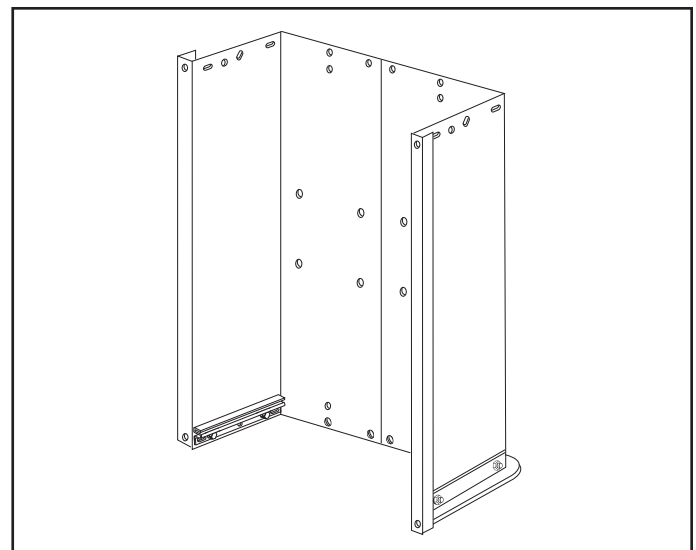

FIGURE 4

- Assemble the front panel over the end of the cart using four 1/4" x 5/8" hex bolts and 1/4" nylock nuts as shown in figure 5. Leave two holes shown in figure 5 empty in the bottom of the panel. Pull the cart body halves together and **tighten** the two bolts in the bottom of the front panel, then **tighten** the bolt in each side.

At this time **tighten** the three bolts in the bottom of the cart which were assembled in step 4.

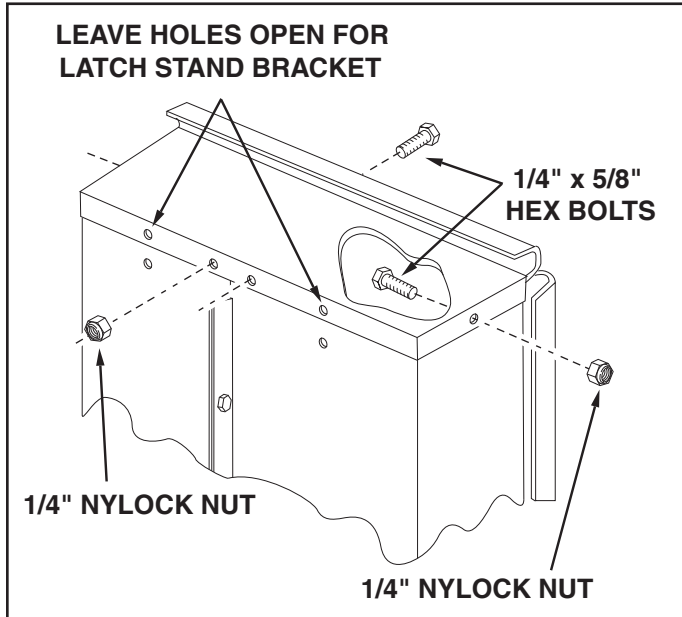

FIGURE 5

- Assemble the wheel support to the cart using eight 5/16" x 3/4" truss head bolts and 5/16" nylock nuts as shown in figure 6. Heads of bolts go to the inside of cart bed. **Tighten**.

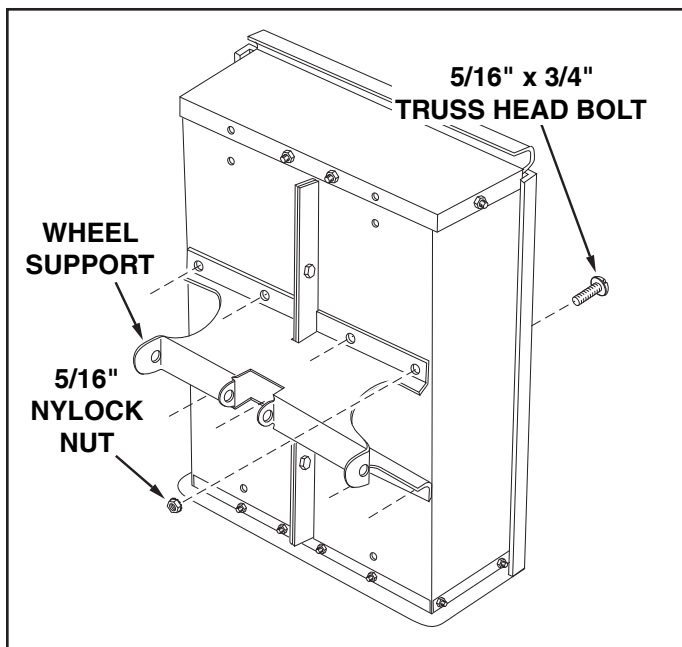

FIGURE 6

- Turn the latch stand bracket so that the aligning tab is at the rear (bottom) of the bracket. Assemble the latch stand bracket to the cart using four 1/4" x 5/8" hex bolts and 1/4" nylock nuts. **TIGHTEN**. See figure 7.

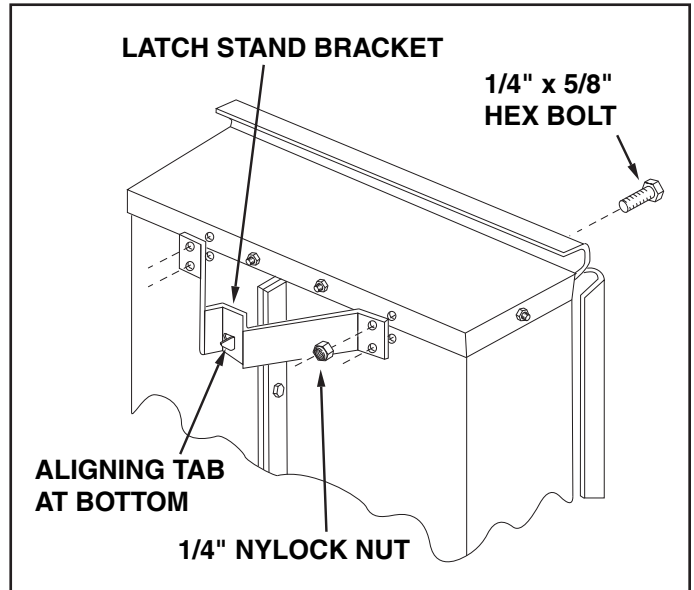

FIGURE 7

- Assemble the two corner caps to the front corners of the cart using four 1/4" x 5/8" hex bolts and 1/4" nylock nuts. Also assemble two 1/4" x 5/8" hex bolts and 1/4" nylock nuts to the two rear corners of the cart. **TIGHTEN**. See figure 8.

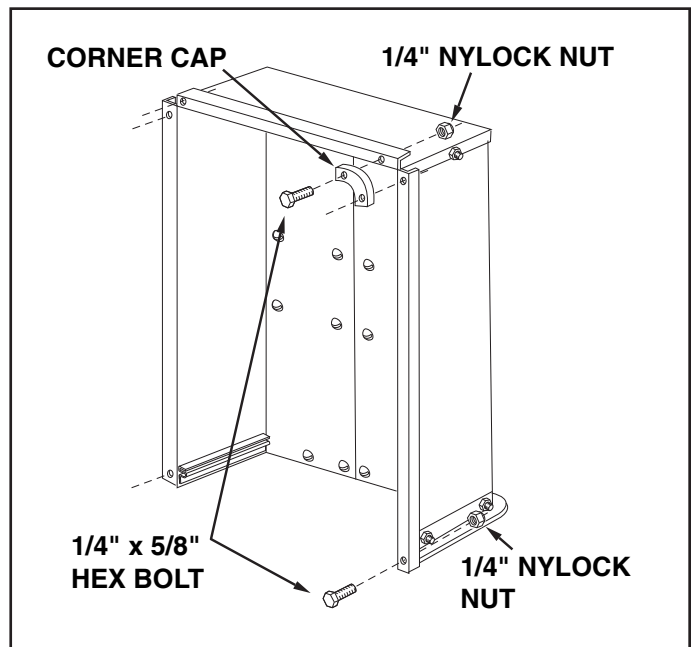

FIGURE 8

13. Insert a flange bearing into each side of the tongue as shown in figure 9.

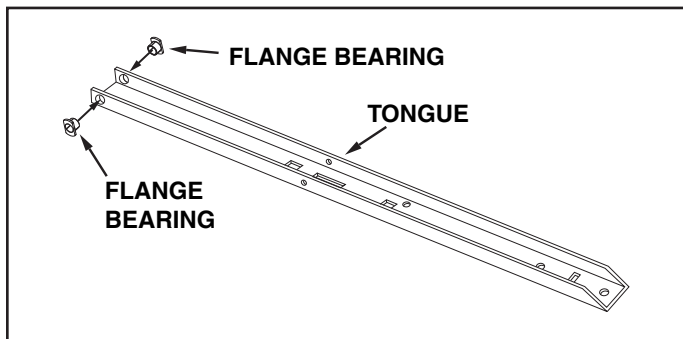

FIGURE 9

14. To prevent accidental tipping during the following assembly procedures, lower the cart to rest upside down on its top flanges, so that the wheel support is facing up. See figure 10.

15. Lay the drawbar tongue (open side facing up) onto the Wheel Support and the Latch Stand Bracket. Assemble the axle through the wheel support and the tongue. See figure 10.

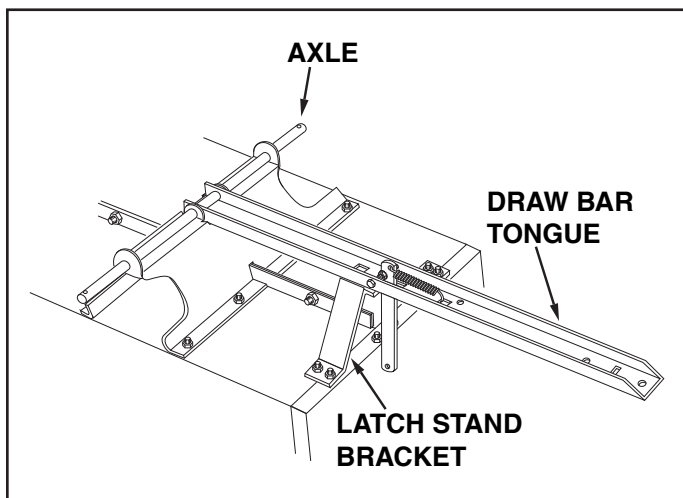

FIGURE 10

16. Place the latch lock lever through the slot in the draw bar tongue as shown in figure 10. Assemble the 5/16" x 3-3/4" hex bolt through the tongue, the lever and two 5/16" hex nuts (SEMS) (one on each side of the lever). Assemble the 5/16" hex lock nut onto the end of the bolt and **tighten** so that the bolt can still rotate freely. **Tighten** the two 5/16" nylock nuts against the sides of the latch lock lever so that the lever is centered in the slot. See figure 11.

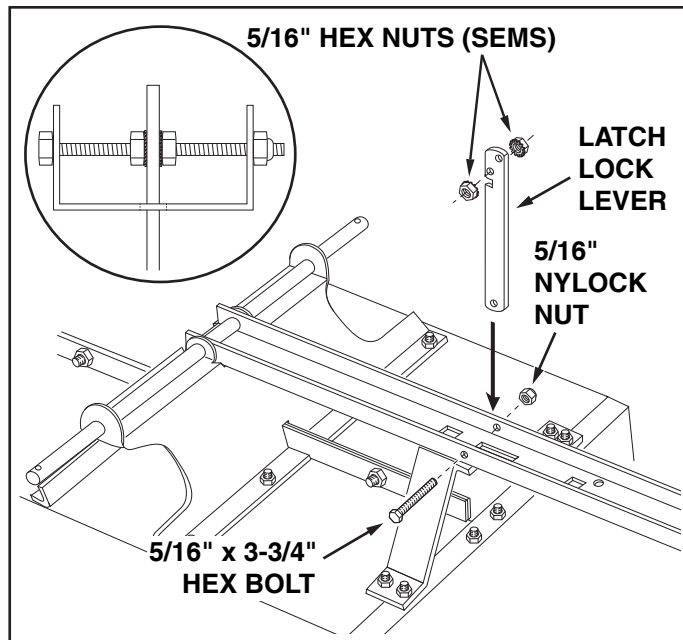

FIGURE 11

17. Hook the **short** end of the spring into the hole in the latch lock lever. Use the spring puller tool to hook the **long** end of the spring into the square hole in the tongue. The spring puller tool can be stored when finished. See figure 12.

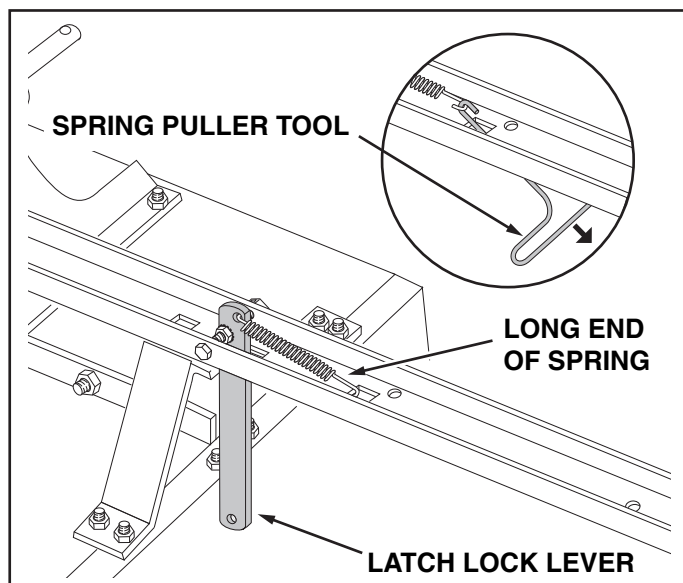

FIGURE 12

IMPORTANT: Make sure drawbar tongue is securely locked to the latch stand bracket by the latch lock lever.

- Assemble an axle clip, a flat washer, a wheel with the valve stem facing out, and another flat washer onto each end of the axle. Place an additional flat washer on each end of the axle if there is space for it. Secure each wheel on the axle with a cotter pin, spreading the ends of the pin around the axle. Press a hub cap onto the flat washer on each end of the axle. See figure 13.

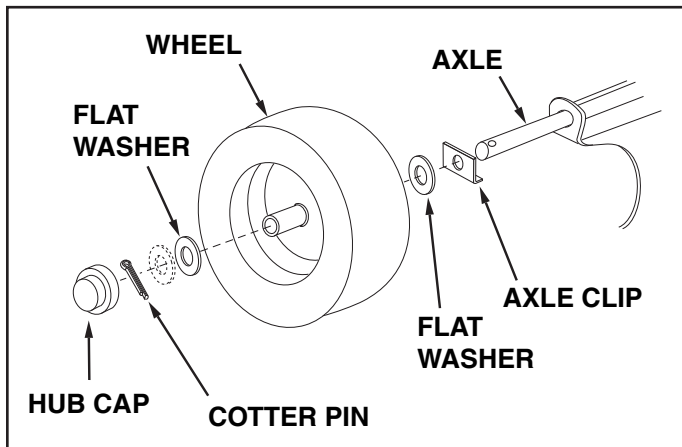

FIGURE 13

- Turn cart over so that it rests right side up on its wheels.
- Assemble the end of the hitch bracket (two holes) down through the slot at the front of the drawbar tongue. Fasten it to the tongue using the 3/8" x 1" hex bolt and 3/8" nylock nut. **Tighten.** See figure 14.
- Assemble the hitch pin through the hitch bracket and the tongue and secure with the 1/8" hair cotter pin. See figure 13.

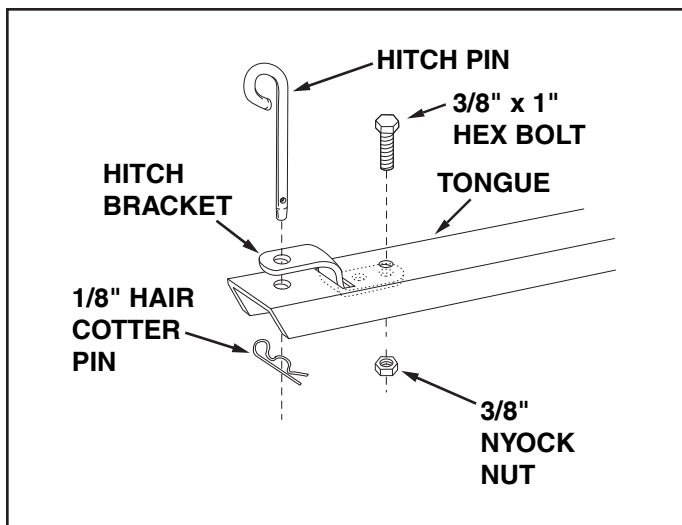

FIGURE 14

- Place the tailgate down into the tailgate guides so that the holes in the bottom lip of tailgate fit over the truss head bolts in the bottom of the cart. This completes the assembly of your cart.

OPERATION



CAUTION: VEHICLE BRAKING AND STABILITY MAY BE AFFECTED WITH THE ADDITION OF AN ACCESSORY OR AN ATTACHMENT. BE AWARE OF CHANGING CONDITIONS ON SLOPES.

- Refer to the vehicle owners manual for instructions about safe operation on slopes.
- Use the slope guide provided on page 11 of this manual to determine if slope angle is too steep for safe operation.
- For best handling and traction, distribute the weight of the load evenly in the cart.
- Always test to make sure your tractor has adequate towing and braking capabilities whenever hauling a substantial amount of weight in your cart. Use extra caution when operating on slopes.



IMPORTANT!

DO NOT EXCEED WEIGHT CAPACITY OF CART

One cubic foot of dirt weighs approximately 80 lbs.

- To dump material from the cart, remove the tailgate by lifting it straight up and out from between the guides. Release the spring latch on the tongue by pulling the latch lock lever forward, away from the cart. The cart bed will then tilt backwards to empty its contents. After emptying, pull the front of the bed down toward the cart tongue until the latch snaps into place. Replace the tailgate if desired.
- The maximum towing speed for this cart is 10 m.p.h.



CAUTION: TO AVOID POSSIBLE INJURY, BEFORE RELEASING THE LATCH BE SURE THAT NO ONE IS NEAR THE CART.

MAINTENANCE

- At the beginning of each season, lubricate, with a light machine oil, the latch, the latch pivot bolt, and the area of the axle where the draw bar tongue pivots.
- Grease or oil the wheel bearings periodically. Use automotive wheel bearing type grease or 20 weight oil.
- Keep tires filled to the recommended tire pressure of printed on the tire.

CART MODEL SPECIFICATIONS

MODELS 45-01012 & 190-653B

Tires:	16.00" x 4.0" Pneumatic
Axle:	3/4" Dia. Steel
Capacity:	Up to 750 Lbs. Max.
Approx. Sh. Wt.	105 Lbs.

REPAIR PARTS FOR UTILITY CARTS MODELS 45-01012 & 190-653B

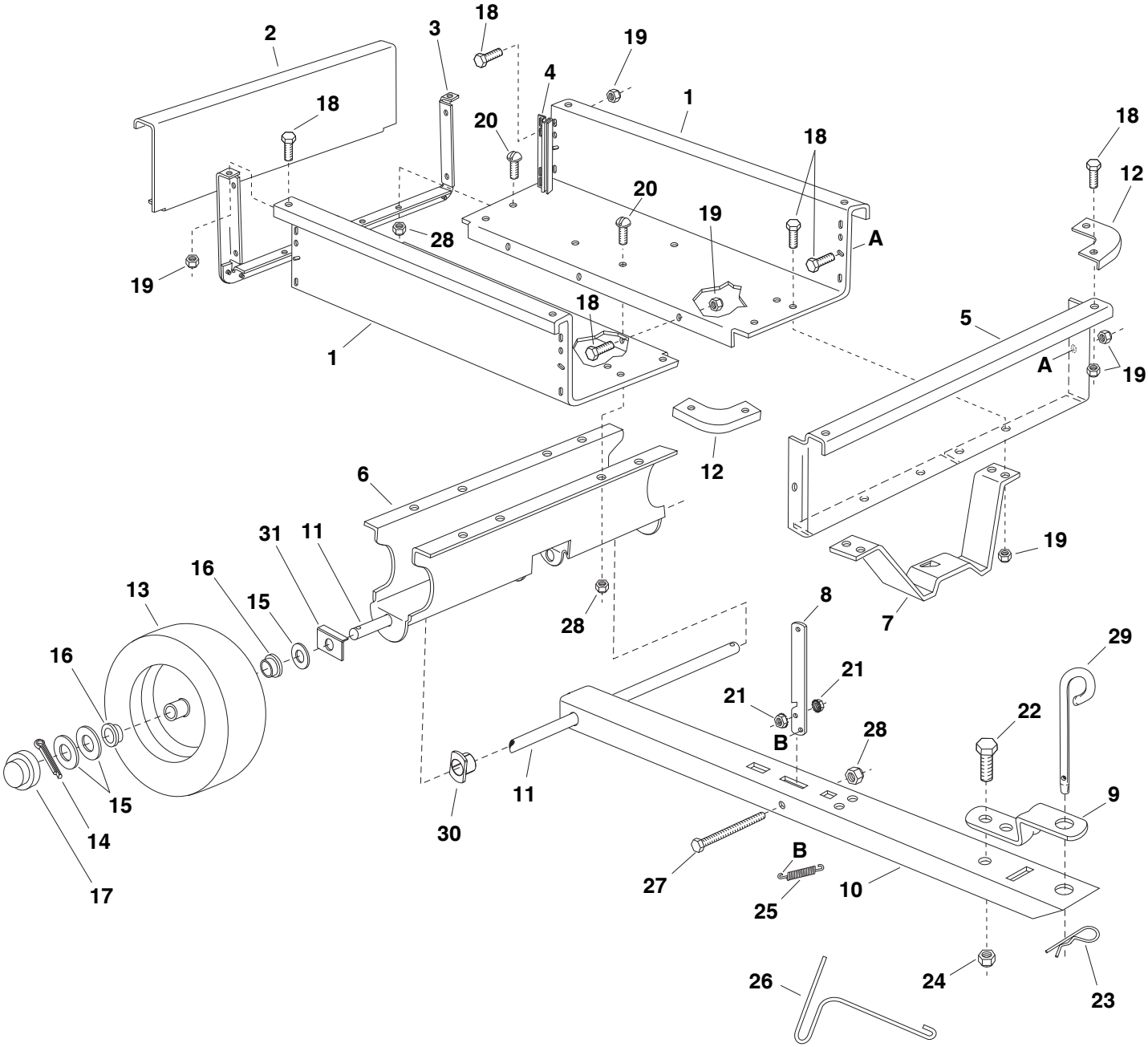

**REPAIR PARTS LIST FOR UTILITY CARTS
MODELS 45-01012, 190-653B**

REF. NO.	PART NO.	DESCRIPTION	45-01012 190-653B
1	23985	Cart Body	2
2	23502	Tailgate	1
3	62458	Tailgate Reinforcement Bracket	1
4	23548	Guide, Tailgate	2
5	23492	Front Panel	1
6	25996	Wheel Support	1
7	24497	Latch Stand Bracket	1
8	24498	Latch Lock Lever	1
9	23014	Hitch Bracket	1
10	24750	Draw Bar Tongue	1
11	24896	Axle, Wheel 3/4" Dia.	1
12	23484	Cap, Front Corner	2
13	43008	Wheel, 16/4.00 x 8.00	2
14	43010	Cotter Pin, 1/8" Dia. x 1" *	2
15	43009	Washer, Flat 3/4" *	6
16	44264	Wheel Bearing	4
17	43014	Hub Cap	2
18	43866	Hex Bolt, 1/4-20 x 5/8" *	21
19	47189	Nylock nut, 1/4-20 (SEMS)	21
20	43814	Truss Hd. Bolt, 5/16-18 x 3/4" Lg.*	12
21	46980	Hex nut, 5/16-18 (SEMS)	2
22	43001	Hex Bolt, 3/8-16 x 1" Lg. *	1
23	43343	Hair Cotter Pin, 1/8" (#4) *	1
24	HA21362	Nylock nut, 3/8-16 *	1
25	47408	Extension Spring	1
26	47622	Spring Puller Tool	1
27	47407	Hex Bolt, 5/16-18 x 3-3/4*	1
28	47810	Nylock Nut, 5/16-18*	13
29	23353	Hitch Pin	1
30	44798	Flange Bearing	2
31	25912	Axle Clip	2
	40311	Owner's Manual	1

* Purchase Common Hardware Locally

NOTES

SLOPE GUIDE

(Keep this sheet in a safe place for future reference.)

Use this guide to determine if a slope is safe for the operation of your tractor and cart. Refer also to the instructions in your vehicle owners manual.

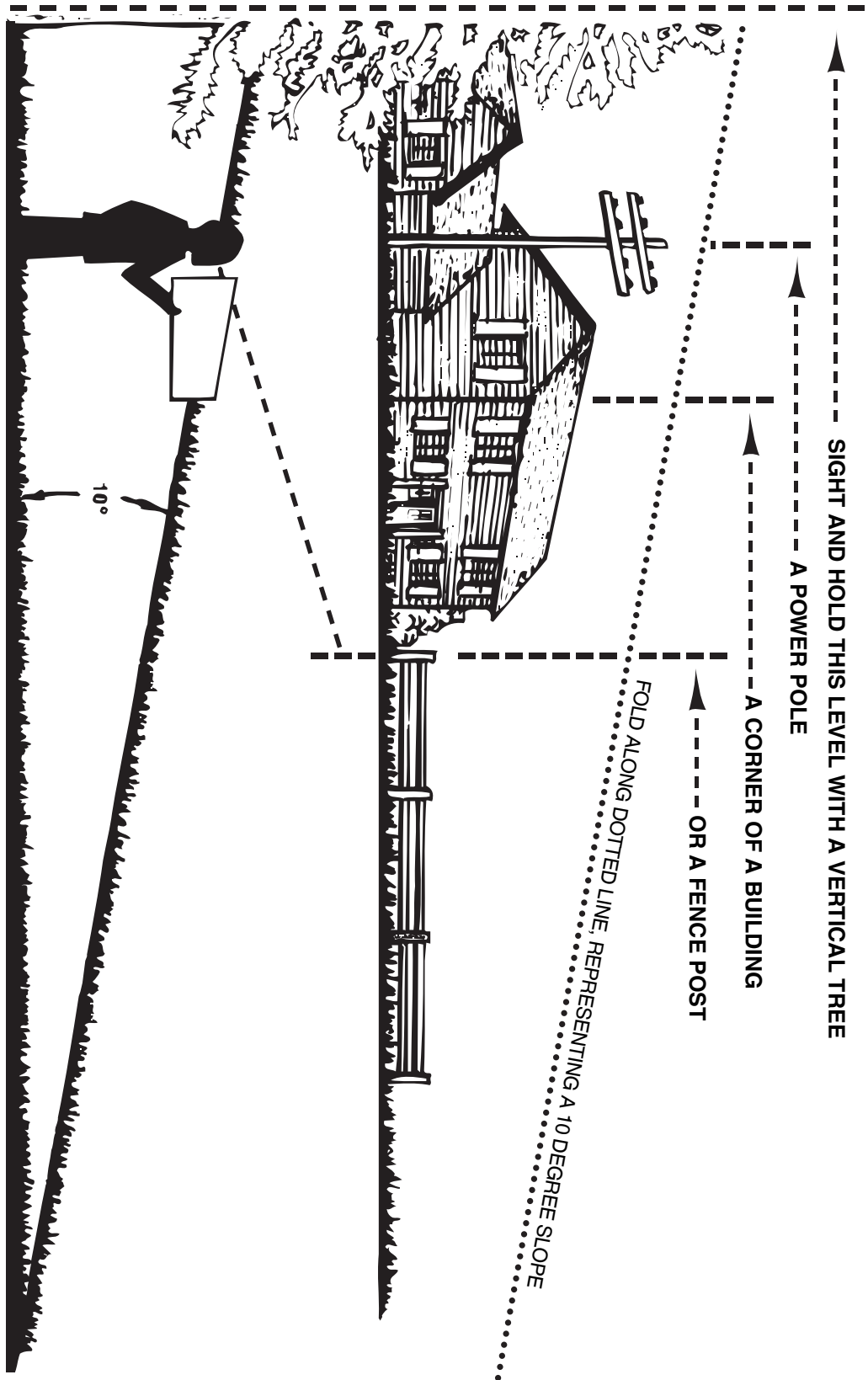

CAUTION: DO NOT OPERATE YOUR TRACTOR AND CART ON A SLOPE IN EXCESS OF 10 DEGREES. BE SURE OF YOUR TRACTOR'S TOWING AND BRAKING CAPABILITIES BEFORE OPERATING ON A SLOPE. AVOID ANY SUDDEN TURNS OR MANEUVERS WHILE ON A SLOPE.

SpeedPart *the fastest way to purchase parts* www.speedepart.com

REPAIR PARTS

Agri-Fab, Inc.
303 West Raymond
Sullivan, IL. 61951
217-728-8388
www.agri-fab.com